



US 20160020260A1

(19) **United States**

(12) **Patent Application Publication**
IM et al.

(10) **Pub. No.: US 2016/0020260 A1**
(43) **Pub. Date: Jan. 21, 2016**

(54) **ORGANIC LIGHT-EMITTING DISPLAY
DEVICE AND METHOD OF
MANUFACTURING THE SAME**

(52) **U.S. CL.**
CPC **H01L 27/3218** (2013.01); **H01L 51/525**
(2013.01); **H01L 27/3246** (2013.01); **H01L**
27/3216 (2013.01); **H01L 27/326** (2013.01)

(71) Applicant: **Samsung Display Co., Ltd.**, Yongin-city
(KR)

(72) Inventors: **Ja-Hyun IM**, Yongin-Si (KR);
Kwan-Hee Lee, Yongin-si (KR);
Beom-Seok KIM, Yongin-si (KR)

(57) **ABSTRACT**

(21) Appl. No.: **14/868,093**

(22) Filed: **Sep. 28, 2015**

Related U.S. Application Data

(63) Continuation of application No. 13/476,681, filed on
May 21, 2012, now Pat. No. 9,190,457.

(30) **Foreign Application Priority Data**

Jun. 13, 2011 (KR) 10-2011-0057028

Publication Classification

(51) **Int. Cl.**
H01L 27/32 (2006.01)
H01L 51/52 (2006.01)

An organic light-emitting display device includes a substrate, a plurality of pixel electrodes arranged in a matrix on the substrate, and an organic common layer covering the pixel electrodes. The pixel electrodes include a plurality of first pixel electrodes, a plurality of second pixel electrodes, and a plurality of third pixel electrodes. An n-th pixel column includes the second pixel electrodes; and the third pixel electrodes arranged alternately, an (n+1)-th pixel column which is adjacent to the n-th pixel column includes the first pixel electrodes, and an (n+2)-th pixel column which is adjacent to the (n+1)-th pixel column includes the second pixel electrodes and the third pixel electrodes arranged alternately, wherein n is a natural number. One of the second and third pixel electrodes is disposed in the n-th pixel column in a row and the other one of the second and third pixel electrodes is disposed in the (n+2)th pixel column in the same row.

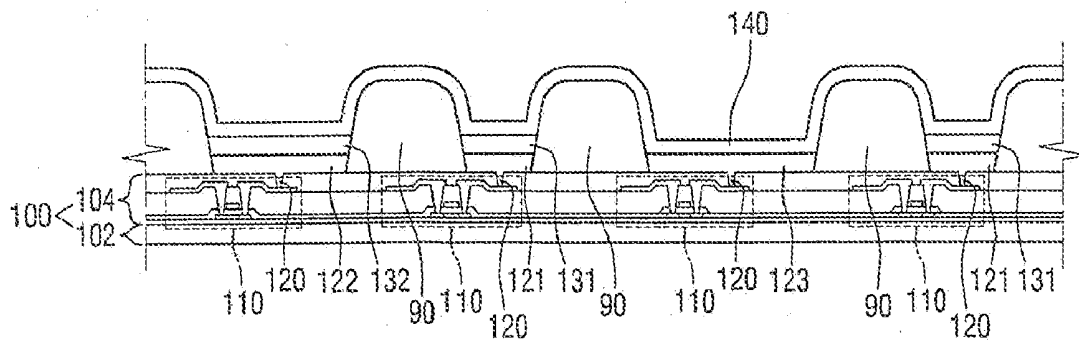

FIG. 1

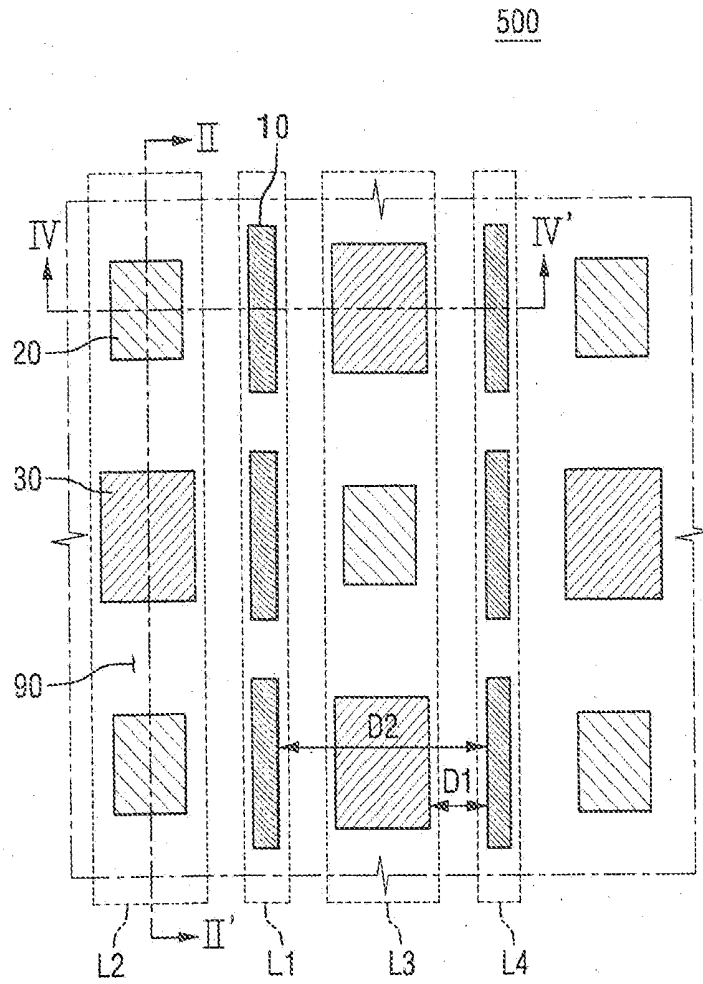

FIG. 3

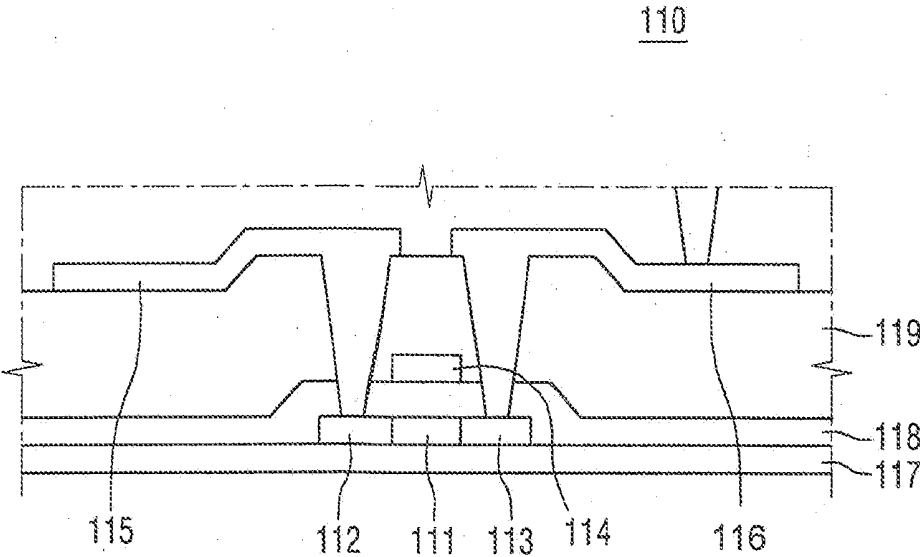

FIG. 4

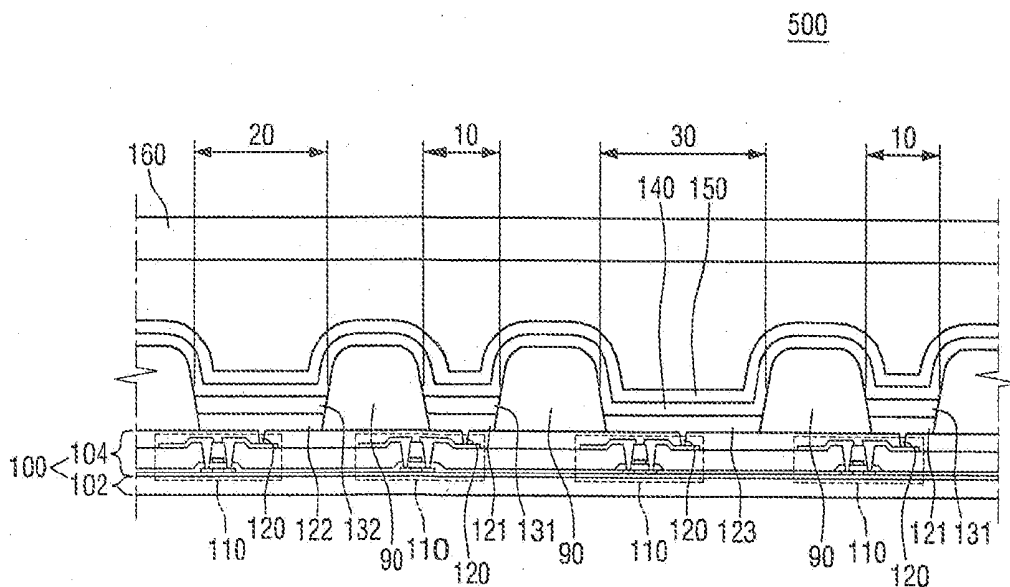

FIG. 5

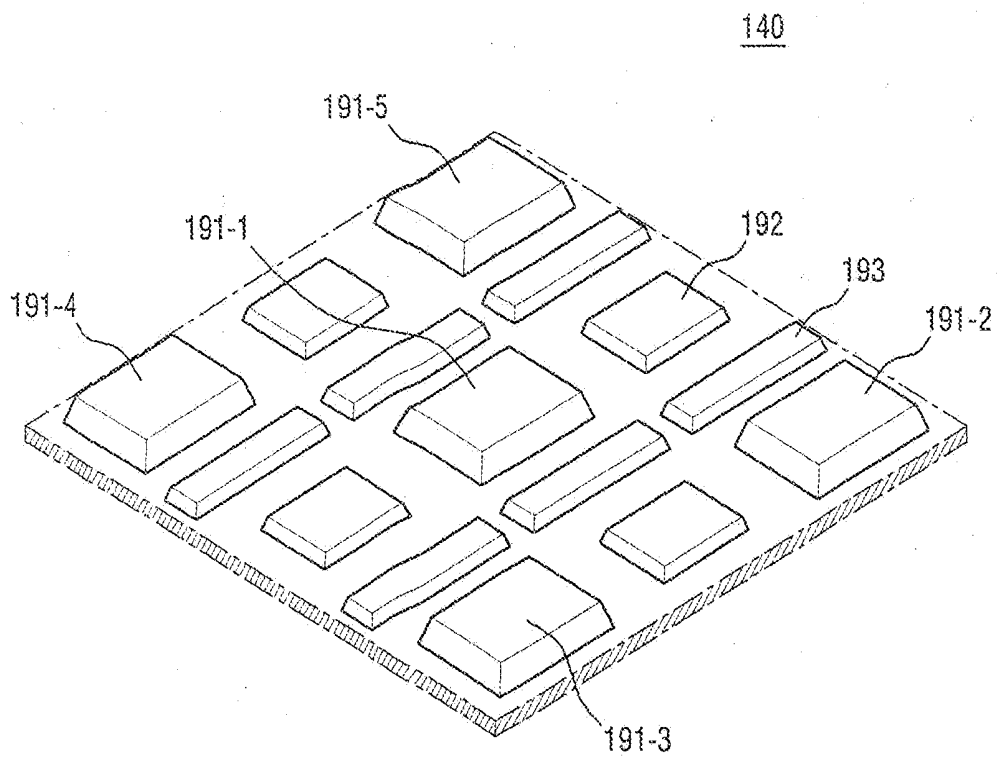

FIG. 6

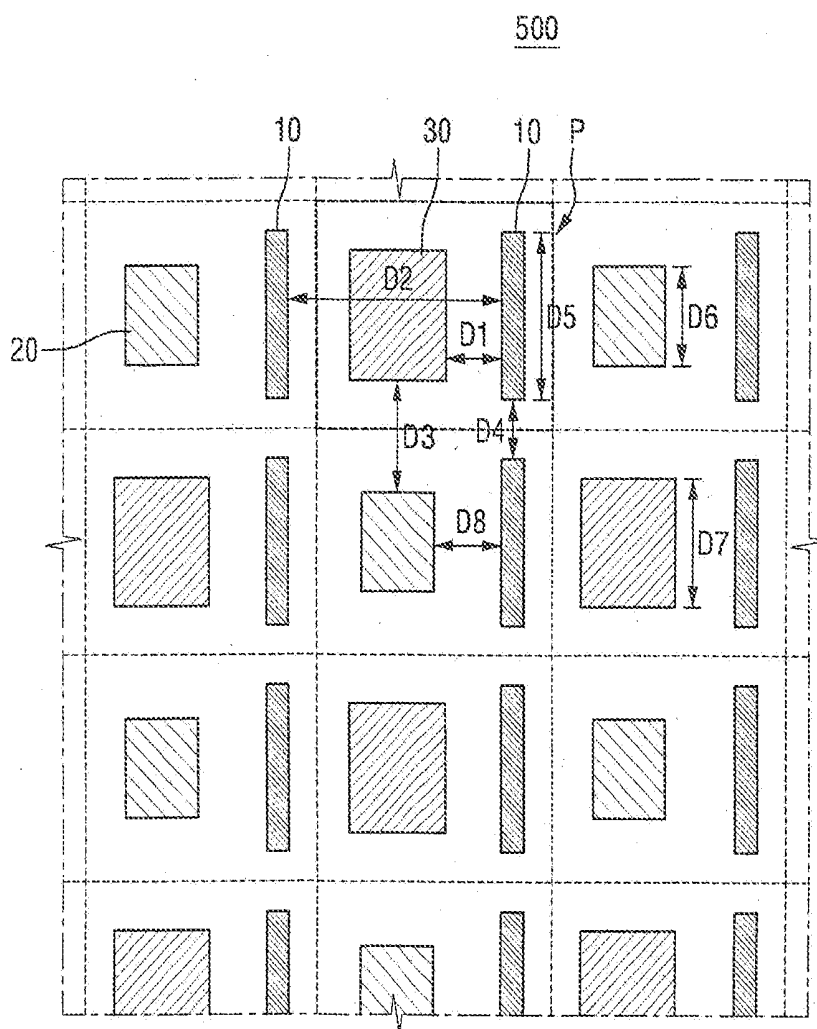

FIG. 7

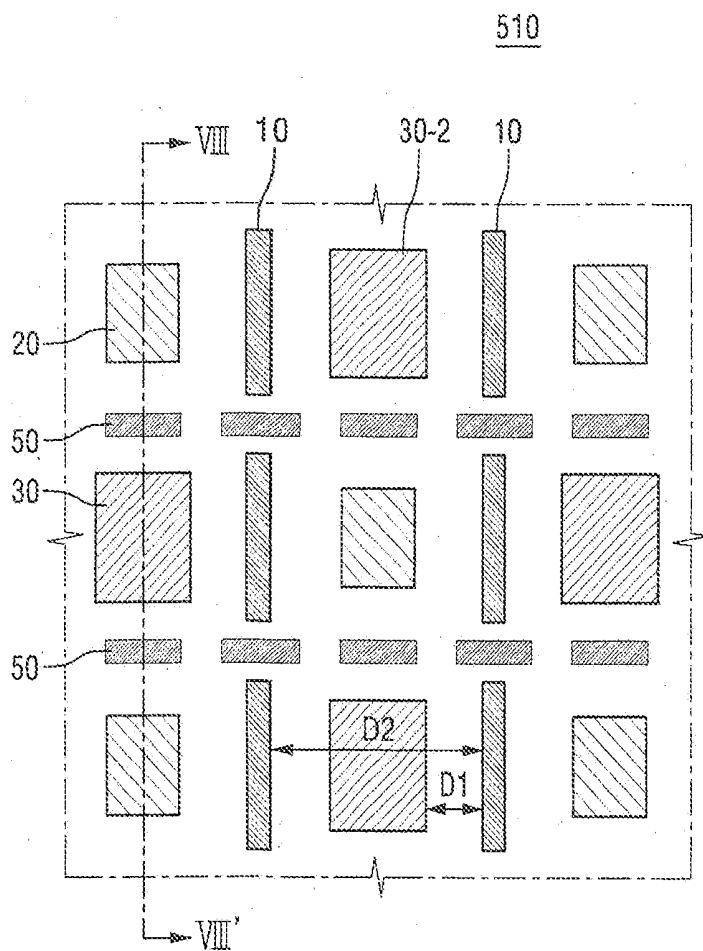

FIG. 8

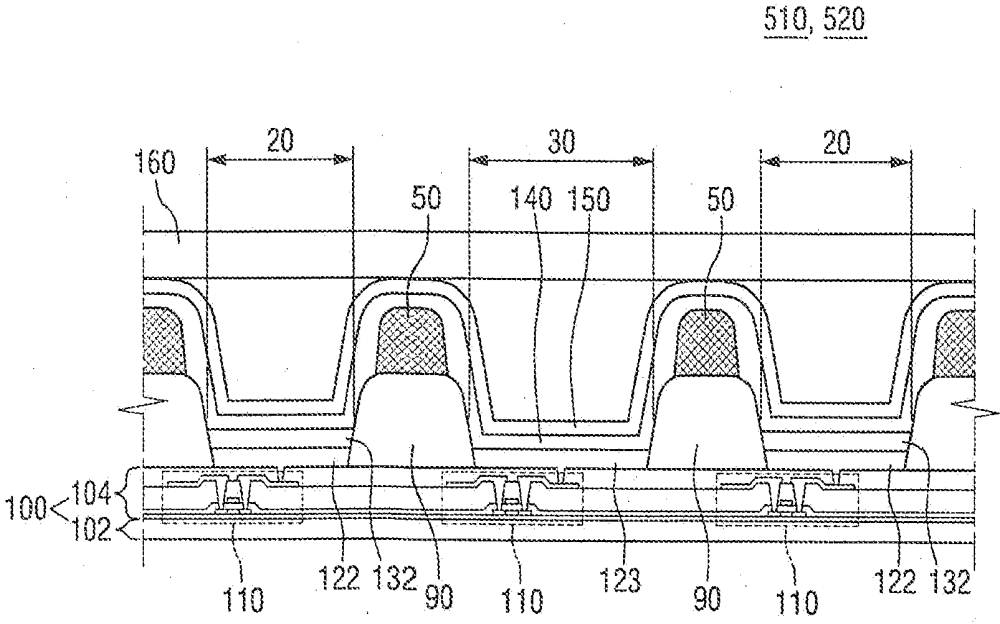

FIG. 9

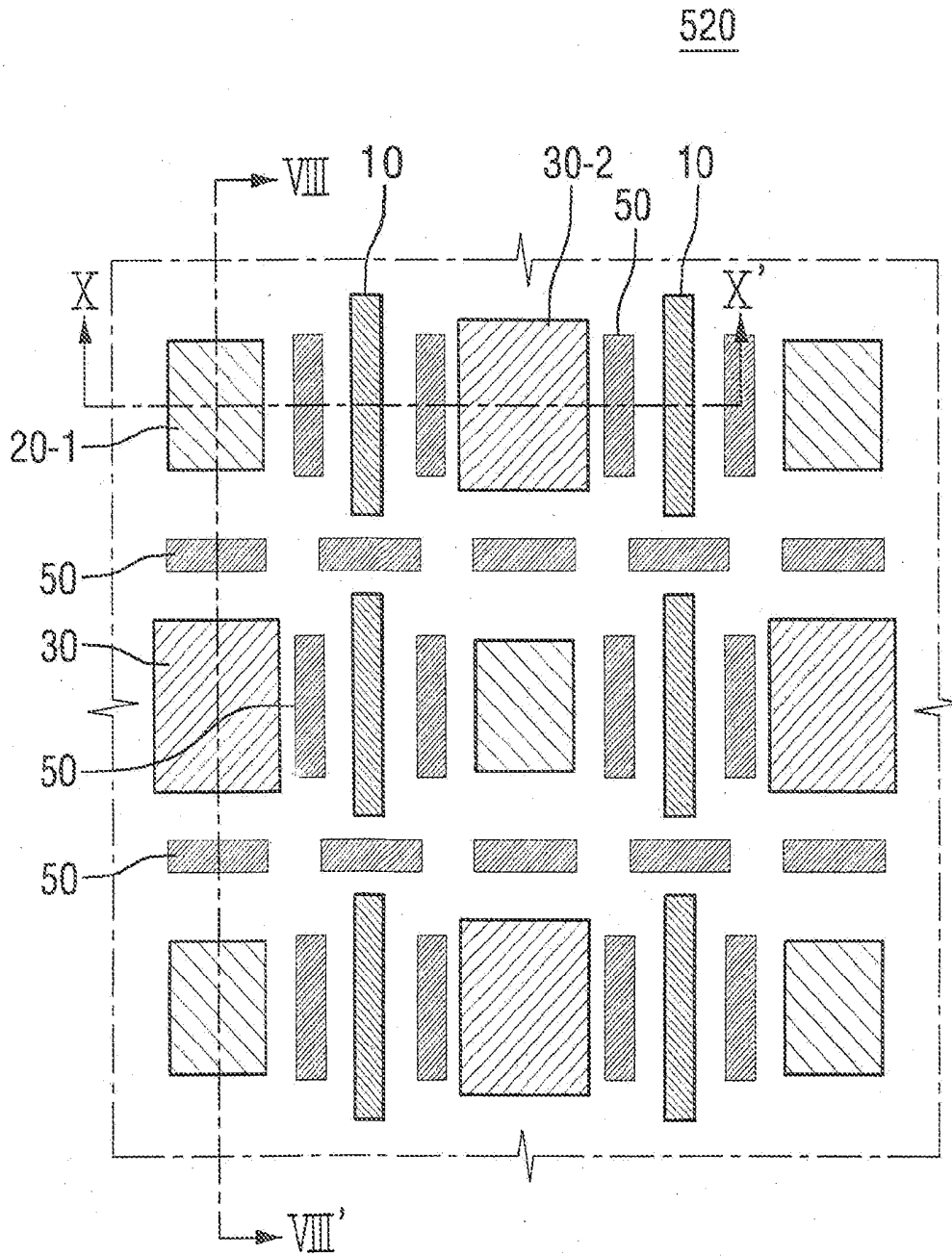

FIG. 10

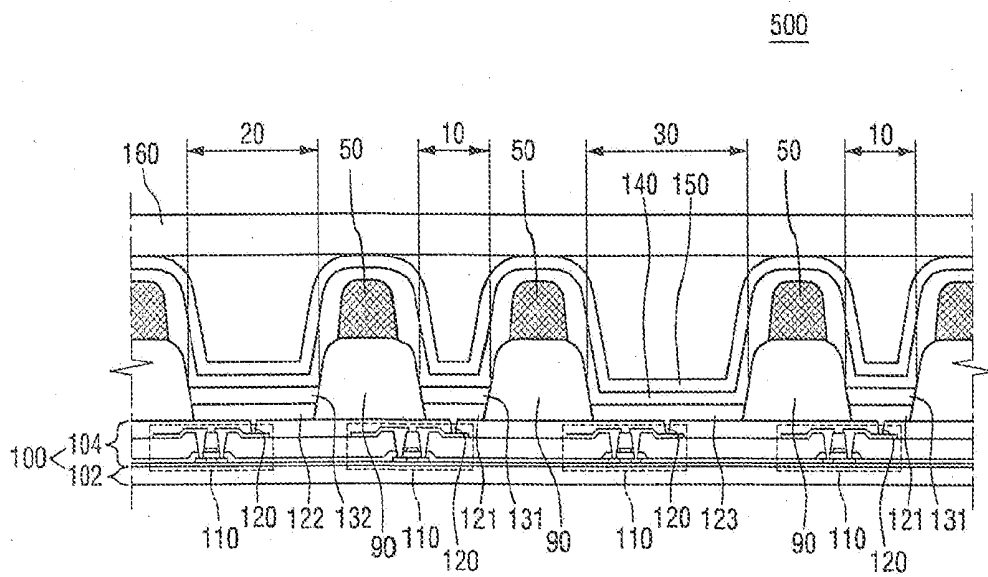

FIG. 11

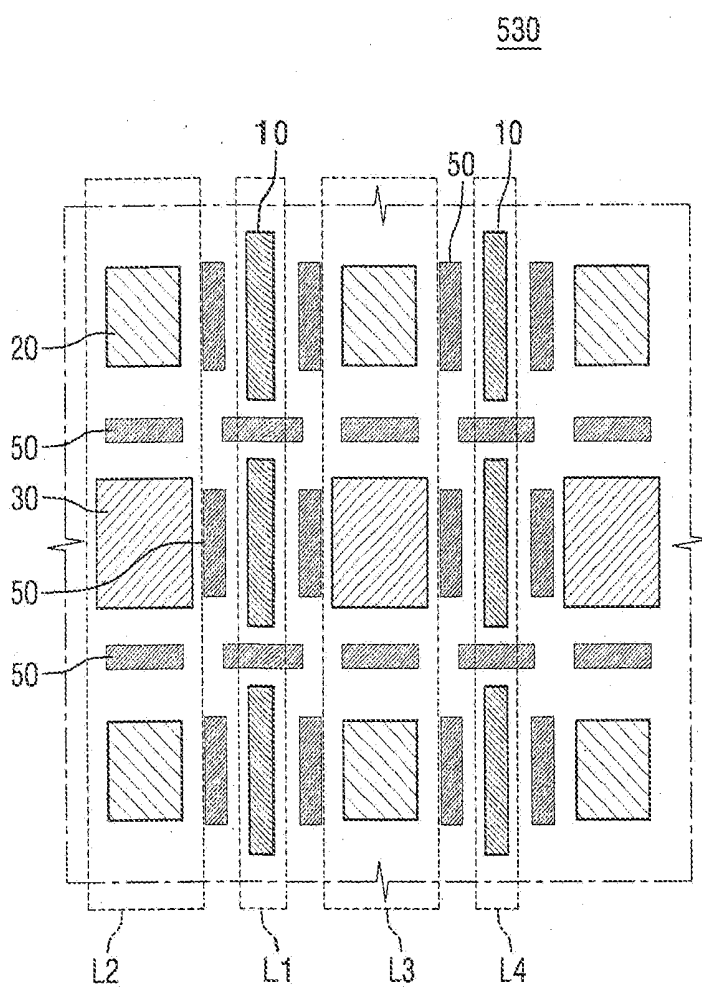

FIG. 12a

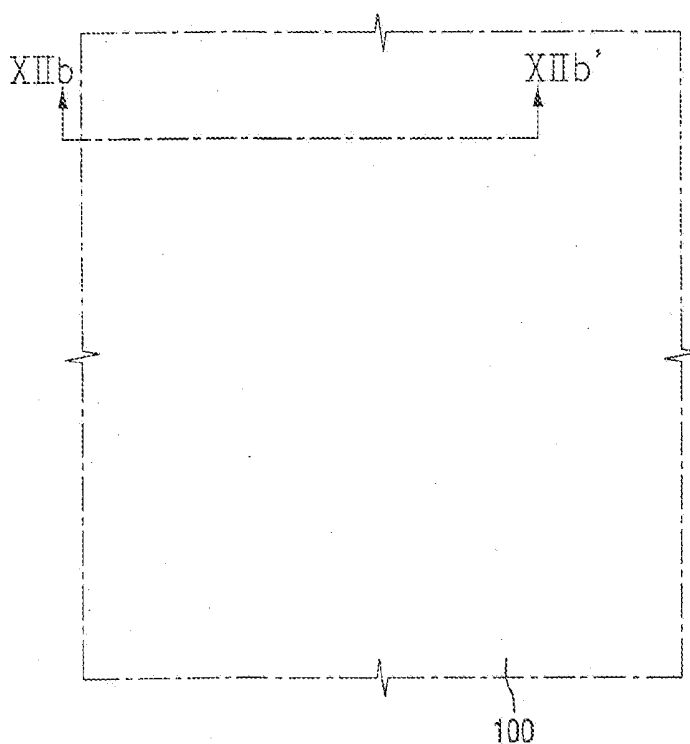

FIG. 12b

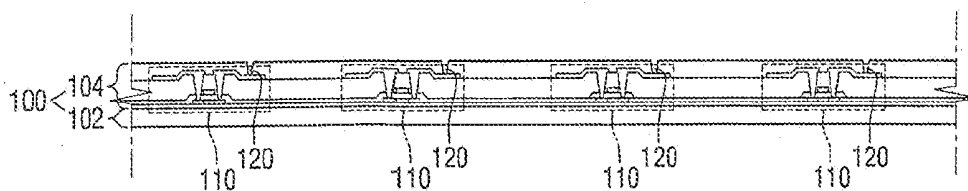

FIG. 13a

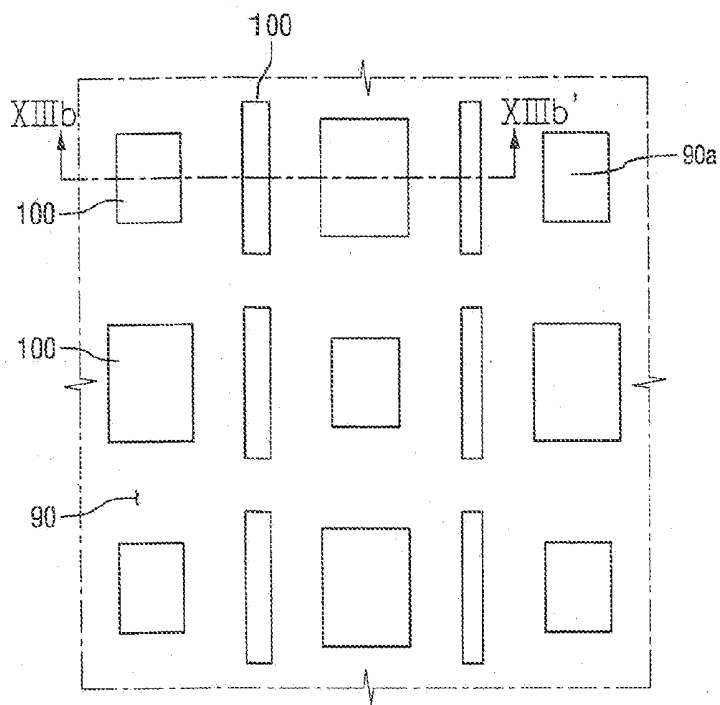

FIG. 13b

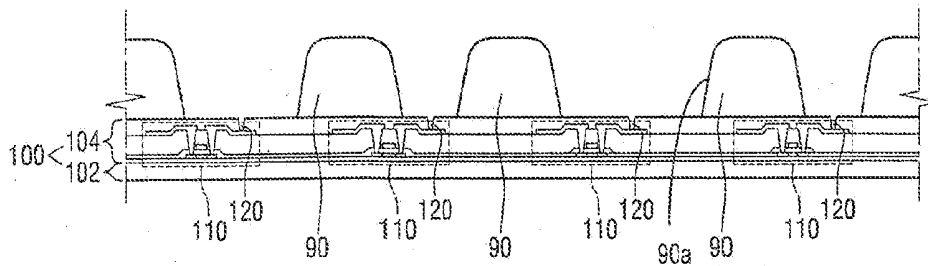

FIG. 14a

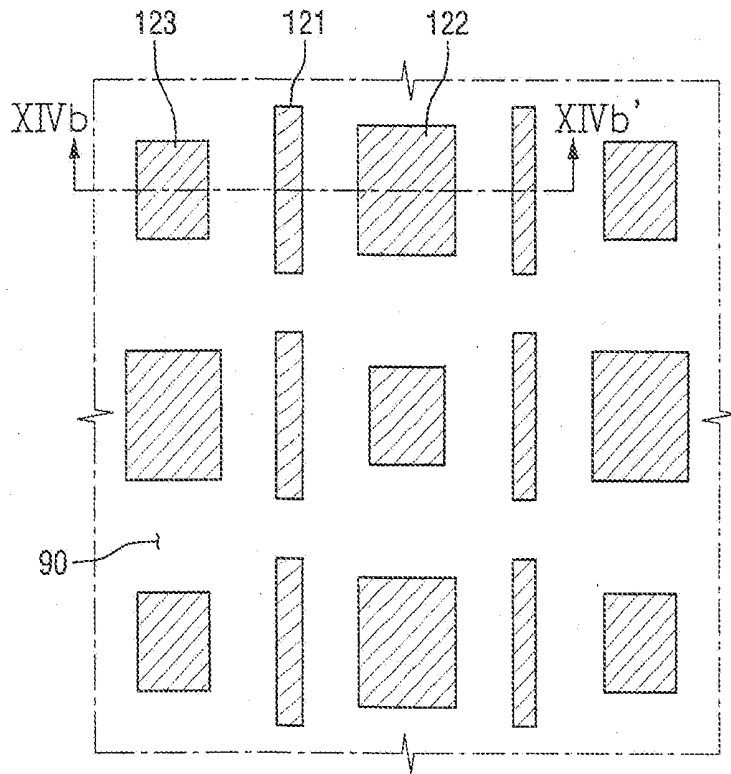

FIG. 14b

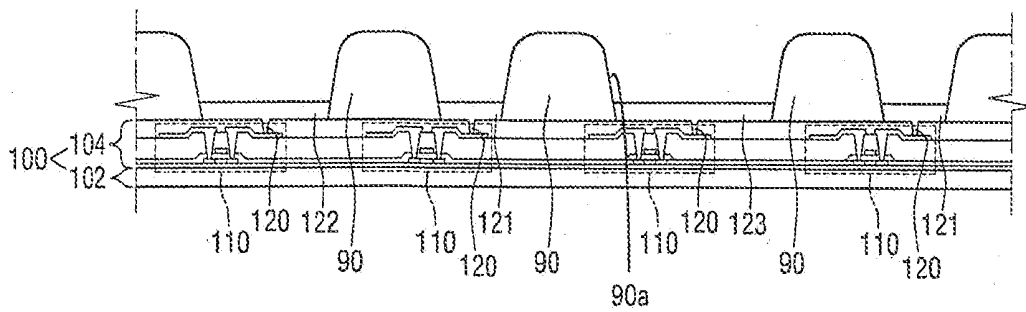

FIG. 15a

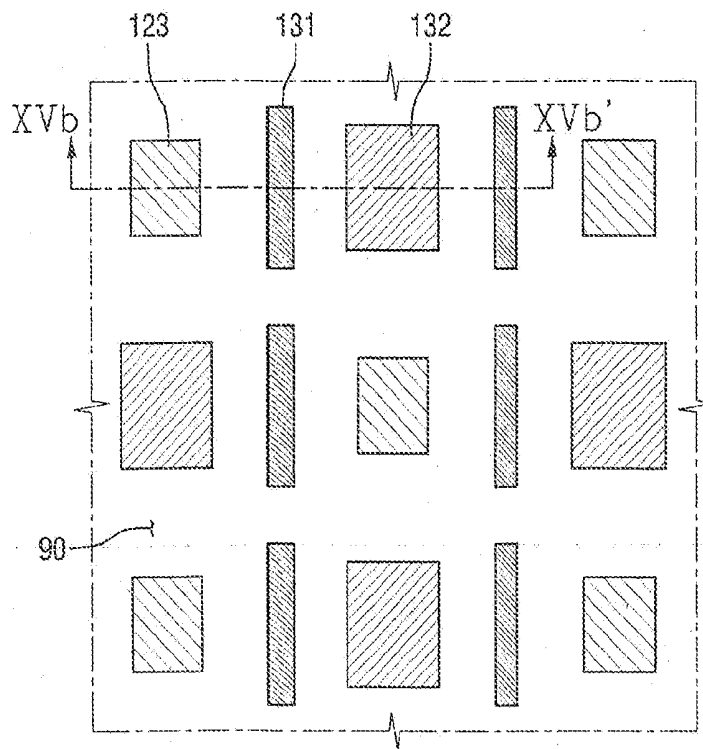

FIG. 15b

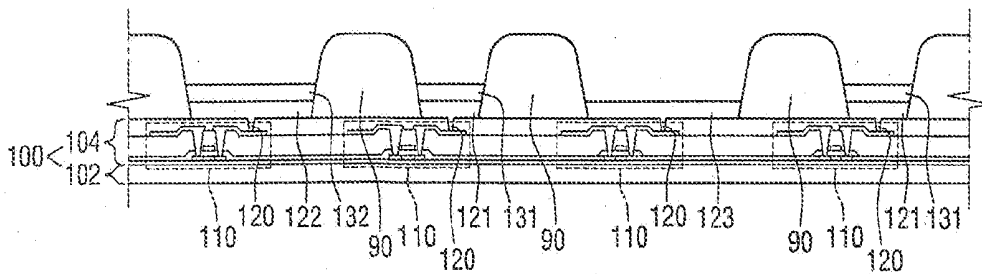

FIG. 16a

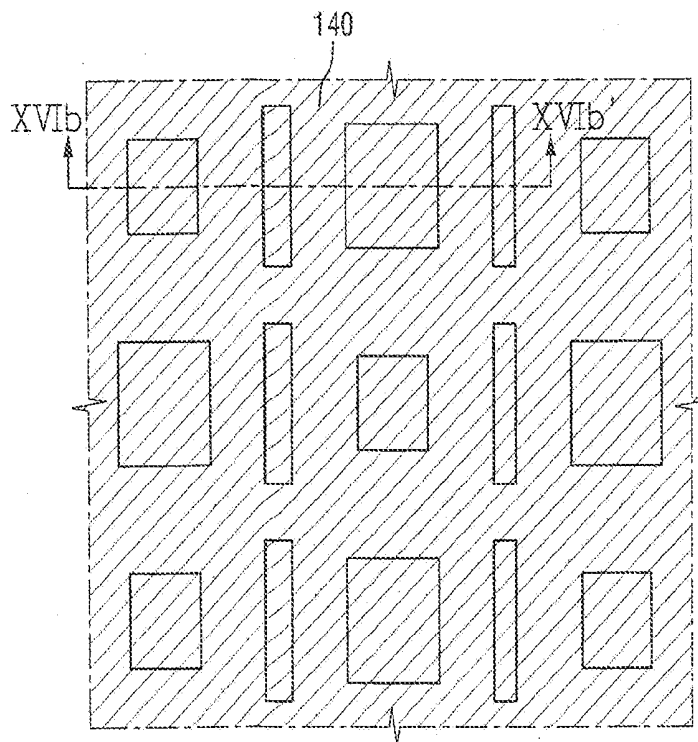
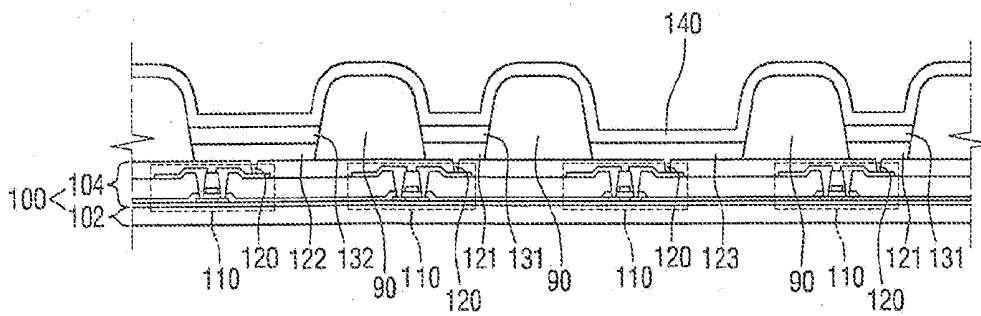

FIG. 16b



**ORGANIC LIGHT-EMITTING DISPLAY
DEVICE AND METHOD OF
MANUFACTURING THE SAME**

CLAIM OF PRIORITY

[0001] This application is a continuation of U.S. patent application Ser. No. 13/476,681, filed on 21 May 2012, which claims priority to and the benefit of Korean Patent Application No. 10-2011-0057028 filed in the Korean Intellectual Property Office on the 13 Jun. 2011, the entire contents of all which are incorporated herein by reference.

BACKGROUND OF THE INVENTION

[0002] 1. Field of the Invention

[0003] The present invention relates to an organic light-emitting display device and a method of manufacturing the same, and more particularly, to an organic light-emitting display device including an organic common layer and a method of manufacturing the organic light-emitting display device.

[0004] 2. Description of the Related Art

[0005] The rapid development of the information technology (IT) industry is dramatically increasing the use of display devices. Recently, there have been demands, for display devices that are lightweight and thin, consume low power and provide high resolution. To meet these demands, liquid crystal displays or organic light-emitting displays using organic light-emitting characteristics are being developed.

[0006] In particular, organic light-emitting displays have a wider viewing angle and operate at higher speed than liquid crystal displays, and rapid technological developments are being made to meet the market demands for flexible display devices.

SUMMARY OF THE INVENTION

[0007] Aspects of the present invention provide an improved organic light-emitting display device.

[0008] Aspects of the present invention also provide an improved organic light-emitting display device which can be manufactured by a reduced number of deposition, processes using fine metal masks.

[0009] Aspects of the present invention further provide an organic light-emitting display device which has a reduced defect rate caused by intrusion of an organic layer in a pixel into another pixel.

[0010] Aspects of the present invention are, however, not restricted to the one set forth herein. The above and other aspects of the present invention will become more apparent to one of ordinary skill in the art to which the present invention pertains by referencing the detailed description of the present invention given below.

[0011] According to an aspect of the present invention, there is provided an organic light-emitting display device constructed with a substrate, a plurality of pixel electrodes arranged in a matrix on the substrate, and an organic common layer covering the pixel electrodes. The pixel electrodes include a plurality of first pixel electrodes, a plurality of second pixel electrodes, and a plurality of third pixel electrodes. An n-th pixel, column includes the second pixel electrodes and the third pixel electrodes arranged alternately, an (n+1)-th pixel column which is adjacent to the n-th pixel column includes the first pixel electrodes, and an (n+2)-th pixel column which is adjacent to the (n+1)-th pixel column includes the second pixel electrodes and the third pixel elec-

trodes arranged alternately, wherein n is a natural number. One of the second and third pixel electrodes is disposed in the n-th pixel column in a row and the other one of the second and third pixel electrodes is disposed in the (n+2)-th pixel column in the same row.

[0012] According to another aspect of the present invention, there is provided a method of manufacturing an organic light-emitting display device. The method includes preparing a substrate, forming a pixel defined layer, which includes a plurality of apertures arranged in a matrix, on the substrate, placing first through third pixel electrodes in the apertures on the substrate, forming a first organic layer on each of the first pixel electrodes, forming a second organic layer on each of the second pixel electrodes, forming an organic common layer on the first organic layer, the second organic layer and each of the third pixel electrodes as a common layer, and forming a common electrode on the organic common layer. An n-th pixel column includes the second pixel electrodes and the third pixel electrodes arranged alternately, an (n+1)-th pixel column which is adjacent to the n-th pixel column includes the first pixel electrodes, and an (n+2)-th pixel column which is adjacent to the (n+1)-th pixel column includes the second pixel electrodes and the third pixel electrodes arranged alternately, wherein n is a natural number. One of the second and third pixel electrodes is disposed in the n-th pixel column in a row and the other one of the second and third pixel electrodes is disposed in the (n+2)-th pixel column in the same row.

[0013] The above and other features and advantages of the present invention will become more apparent by describing in detail exemplary embodiments thereof with reference to the attached drawings in which.

BRIEF DESCRIPTION OF THE DRAWINGS

[0014] A more complete appreciation of the invention, and many of the attendant advantages thereof will be readily apparent as the same becomes better understood by reference to the following detailed description when considered in conjunction with the accompanying drawings, in which like reference symbols indicate the same or similar components, wherein:

[0015] FIG. 1 is a layout view of an organic light-emitting display device constructed as an exemplary embodiment according to the principles of the present invention;

[0016] FIG. 2 is a cross-sectional view of the organic light-emitting display device of FIG. 1 taken along line II-II' of FIG. 1;

[0017] FIG. 3 is an enlarged cross-sectional view of a pixel driving portion of FIG. 1 constructed as the exemplary embodiment according to the principles of the present invention;

[0018] FIG. 4 is a cross-sectional view of the organic light-emitting display device of FIG. 1 taken along line IV-IV' of FIG. 1;

[0019] FIG. 5 is a bottom perspective view of a portion of an organic common layer of FIG. 1 constructed as the exemplary embodiment according to the principles of the present invention;

[0020] FIG. 6 is a layout view of the organic light-emitting display device of FIG. 1 constructed as the exemplary embodiment according to the principles of the present invention;

[0021] FIG. 7 is a layout view of an organic light-emitting display device constructed as another exemplary embodiment according to the principles of the present invention;

[0022] FIG. 8 is a cross-sectional view of the organic light-emitting display device of FIG. 7 taken along line VIII-VIII' of FIG. 7;

[0023] FIG. 9 is a layout view of an organic light-emitting display device constructed as another exemplary embodiment according to the principles of the present invention;

[0024] FIG. 10 is a cross-sectional view of the organic light-emitting display device of FIG. 9 taken along line X-X' of FIG. 9;

[0025] FIG. 11 is a layout view of an organic light-emitting display device constructed as another exemplary embodiment according to the principles of the present invention;

[0026] FIGS. 12A, 13A, 14A, 15A and 16A are layout views sequentially illustrating processes in a method of manufacturing an organic light-emitting display device as an exemplary embodiment according to the principles of the present invention;

[0027] FIG. 12B is a cross-sectional view of the organic light-emitting display device of FIG. 12A taken along line XIIb-XIIb' of FIG. 12A;

[0028] FIG. 13B is a cross-sectional view of the organic light-emitting display device of FIG. 13A taken along line XIIIb-XIIIb' of FIG. 13A;

[0029] FIG. 14B is a cross-sectional view of the organic light-emitting display device of FIG. 14A taken along line XIVb-XIVb' of FIG. 14A;

[0030] FIG. 15B is a cross-sectional view of the organic light-emitting display device of FIG. 15A taken along line XVb-XVb' of FIG. 15A; and

[0031] FIG. 16B is a cross-sectional view of the organic light-emitting display device of FIG. 16A taken along line XVIb-XVIb' of FIG. 16A.

DETAILED DESCRIPTION OF THE INVENTION

[0032] An organic light-emitting display includes a plurality of organic layers, each containing a material that emits red, green or blue light. Each of the organic layers is formed by a deposition process using a separate fine metal mask. Therefore, a number of complicated deposition processes using fine metal masks are required.

[0033] In an organic light-emitting display, if an organic layer being deposited in a target pixel using a fine metal mask intrudes into a neighboring pixel, when the neighboring pixel emits light, the organic layer may also emit light, thus causing pixel defects.

[0034] The present invention will now be described more fully hereinafter with reference to the accompanying drawings, in which preferred embodiments of the invention are shown. This invention may, however, be embodied in different forms and should not be construed as limited to the embodiments set forth herein. Rather, these embodiments are provided so that this disclosure will be thorough and complete, and will fully convey the scope of the invention to those skilled in the art. The same reference numbers indicate the same components throughout the specification. In the attached figures, the thickness of layers and regions is exaggerated for clarity.

[0035] It will also be understood that when a layer is referred to as being "on" another layer or substrate, it can be directly on the other layer or substrate, or intervening layers

may also be present. In contrast, when an element is referred to as being "directly on" another element, there are no intervening elements present.

[0036] Hereinafter, exemplary embodiments of the present invention will be described with reference to the attached drawings.

[0037] FIG. 1 is a layout view of an organic light-emitting display device 500 constructed as an exemplary embodiment according to the principles of the present invention.

[0038] FIG. 2 is a cross-sectional view taken along line II-II' of FIG. 1. FIG. 3 is an enlarged cross-sectional view of a pixel driving portion 110 constructed as the exemplary embodiment of FIG. 1. FIG. 4 is a cross-sectional view taken along line IV-IV of FIG. 1.

[0039] Referring to FIGS. 1 through 4, the organic light-emitting display device 500 constructed as the current exemplary embodiment according to the principles of the present invention includes a first substrate 100, a pixel defined layer 90, a plurality of pixel electrodes including first through third pixel electrodes 121 through 123, first through third organic layers 131, 132 and 140, a common electrode 150, and a second substrate 160 disposed above the common electrode 150.

[0040] The first substrate 100 includes a first insulating substrate 102 and a driving element layer 104 disposed on the first insulating substrate 102.

[0041] The first insulating substrate 102 may be a transparent insulating substrate made of glass, quartz, ceramic, or plastic. The first insulating substrate 102 may be a flat plate-shaped substrate or a flexible substrate which can be easily bent by an external force.

[0042] The driving element layer 104 is disposed on the first insulating substrate 102 and includes a plurality of pixel driving portions 110 for driving the organic light-emitting display device 500 and various wirings such as data lines. The driving element layer 104 may be formed as a single layer or a multilayer.

[0043] Each of the pixel driving portions 110 may be connected to any one of the first through third pixel electrodes 121 through 123 by a first through hole 120 and may control current supplied to the connected one of the first through third pixel electrodes 121 through 123.

[0044] More specifically, referring to FIG. 3, each of the pixel driving portions 110 may include a buffer layer 117, a semiconductor layer (111 through 113), a gate insulating film 118, an interlayer insulating film 119, a driving gate electrode 114, a driving source electrode 115, and a driving drain electrode (not shown).

[0045] The buffer layer 117 prevents penetration of impurity elements into the first substrate 100 and planarizes the surface of the first substrate 100. The buffer layer 117 may be made of various materials that can perform these functions. For example, the buffer layer 117 may be any one of a SiN_x layer, a SiO₂ layer, and a SiO_xN_y layer. The buffer layer 117 is not essential and can be omitted depending on the type of the first substrate 100 and processing conditions.

[0046] The driving semiconductor layer 111 through 113 is formed on the buffer layer 117. The driving semiconductor layer may be made of an amorphous silicon film or a polycrystalline silicon film. However, the polycrystalline silicon film is preferred. In addition, the driving semiconductor layer includes a channel region 111 which is undoped with impurities and a source region 112 and a drain region 113 which are formed on both sides of the channel region 111 and are

p+-doped. Here, an ion material used to dope the source and drain regions **112** and **113** is P-type impurities such as boron (B). For example, B_2H_6 , may be used. The impurities may vary according to the type of a thin-film transistor (TFT).

[0047] The gate insulating film **118** is formed of SiN_x or SiO_2 on the driving semiconductor layer (**111** through **113**). A gate wiring including the driving gate electrode **114** is formed on the gate insulating film **118**. The gate wiring further includes a gate line (not shown) and other wirings. The driving gate electrode **114** may overlap at least part (in particular, the channel region **111**) of the driving semiconductor layer (**111** through **113**).

[0048] The interlayer insulating film **119** covering the driving gate electrode **114** is formed on the gate insulating film **118**. Through holes penetrate both the gate insulating film **118** and the interlayer insulating film **119** to expose the source region **112** and the drain region **113** of the driving semiconductor layer. Like the gate insulating film **118**, the interlayer insulating film **119** may be made of SiN_x or SiO_2 .

[0049] A data wiring including the driving source electrode **115** and the driving drain electrode **116** is formed on the interlayer insulating film **119**. The data wiring further includes a data line (not shown), a common power supply line (not shown), and other wirings. The driving source electrode **115** and the driving drain electrode **116** may be connected to the source region **112** and the drain region **113** of the driving semiconductor layer by the through holes, respectively.

[0050] The pixel defined layer **90** is formed on the driving element layer **104**. The pixel defined layer **90** may include a plurality of apertures **90a** arranged in a matrix. A pixel region is defined in each of the apertures. That is, the pixel defined layer **90** defines a plurality of pixel regions, and the pixel regions are separated from each other by the pixel defined layer **90**.

[0051] The pixel regions may include first through third pixel regions **10** through **30** which emit light of different colors. In the current exemplary embodiment, the first pixel regions **10** are regions which emit green light, the second pixel regions **20** are regions which emit red light, and the third pixel regions **30** are regions which emit blue light. In each of the apertures, any one of the first through third pixel electrodes **121** through **123**, which will be described later, may be placed. For example, the first pixel electrode **121** may be disposed in an aperture that defines each of the first pixel regions **10**, the second pixel electrode **122** may be disposed in an aperture that defines each of the second pixel regions **122**, and the third pixel electrode **123** may be disposed in an aperture that defines each of the third pixel regions **30**.

[0052] Each of the first, pixel regions **10** may include the first organic layer **131** formed on the first pixel electrode **121** and the third organic layer **140** formed on the first organic layer **131**, in addition to the first pixel electrode **121**.

[0053] Each of the second pixel regions **20** may include the second organic layer **132** formed on the second pixel electrode **122** and the third organic layer **140** formed on the second organic layer **132**, in addition to the second pixel electrode **122**.

[0054] Each of the third pixel regions **30** may include the third organic layer **140** formed on the third pixel electrode **123**, in addition to the third pixel electrode **123**.

[0055] The first through third pixel electrodes **121** through **123** may be situated on the first substrate **100** and may be connected to the driving drain electrode **116** of each of the pixel driving portions **110** by the first through hole **120**. The

first through third pixel electrodes **121** through **123** may be made of a reflective conductive material, a transparent conductive material, or a semi-transparent conductive material.

[0056] Examples of the reflective conductive material include Li, Ca, LiF/Ca, LiF/Al, Al, Ag, Mg, and Au. Examples of the transparent conductive material include indium tin oxide (ITO), indium zinc oxide (IZO), ZnO, and indium oxide (In_2O_3).

[0057] The semi-transparent conductive material may be a co-deposition material containing one or more of Mg and Ag or may be one or more of Mg, Ag, Ca, Li, and Al.

[0058] The first organic layer **131** is disposed on the first pixel electrode **121**, the second organic layer **132** is disposed on the second pixel electrode **122**, and the third organic layer **140** is disposed on the first organic layer **131**, the second organic layer **132**, the third pixel electrode **123**, and the pixel defined layer **90** as a common layer.

[0059] Since the third organic layer **140** is an organic common layer disposed on the first organic layer **131**, the second organic layer **132**, the third pixel electrode **123** and the pixel defined layer **90**, no fine metal mask is required to deposit the third organic layer **140**. Accordingly, the number of fine metal masks can be reduced.

[0060] In each of the first through third organic layers **131**, **132** and **140**, holes and electrons generated by the common electrode **150** and one of the first through third pixel electrodes **121** through **123** combine together to form excitons. As an energy level of the excitons transits from an excited state to a ground state, each of the first through third organic layers **131**, **132** and **140** emits light of a color corresponding to the changed energy level.

[0061] in some embodiments according to the principles of the present invention, the first organic layer **131** may contain a material that can emit red light, the second organic layer **132** may contain a material that can emit green light, and the third organic layer **140** may contain a material that can emit blue light. In some other embodiments of the present invention, the first organic layer **131** may contain a material that can emit green light, the second organic layer **132** may contain a material that can emit red light, and the third organic layer **140** may contain a material that can emit blue light.

[0062] A highest occupied molecular orbital (HOMO) value of the third organic layer **140** may be higher than those of the first organic layer **131** and the second organic layer **132**. Thus, holes of the first organic layer **131** or the second organic layer **132** are not transported to the third organic layer **140**. Accordingly, the combination of holes and electrons may not occur in regions of the third organic layer **140** which are included in the first and second pixel regions **10** and **20**. As a result, regions of the third organic layer **140** which overlap the first pixel electrodes **121** or the second pixel electrode **122** may not emit light.

[0063] Although not shown in the drawings, in some embodiments of the present invention, a hole transport layer may be interposed between the first organic layer **131** and the first pixel electrode **121**, between the second organic layer **132** and the second pixel electrode **122**, and between the third organic layer **140** and the third pixel electrode **123**. In addition, a hole injection layer may further be interposed between the hole transport layer and each of the first through third pixel electrodes **121** through **123**.

[0064] Although not shown in the drawings, in some embodiments of the present invention, a hole stop layer may be interposed between each of the first through third

organic layers 131, 132 and 140 and the common electrode 150. The hole stop layer between the first organic layer 131 and the common electrode 150 or between the second organic layer 132 and the common electrode 150 can be omitted when the third organic layer 140 has a higher HOMO value than the first organic layer 131 or the second organic layer 132.

[0065] The common electrode 150 is formed on the third organic layer 140, and a potential applied to the common electrode 150 may form a potential difference between the common electrode 150 and one of the first through third pixel electrodes 121 through 123.

[0066] The common electrode 150 may be made of a reflective conductive material, a transparent conductive material, or a semi-transparent conductive material.

[0067] Examples of the reflective conductive material include Li, Ca, LiF/Ca, LiF/AL AL Ag, Mg, and Au. Examples of the transparent conductive material include ITO, IZO, ZnO, and In₂O₃.

[0068] The semi-transparent conductive material may be a co-deposition material containing one or more of Mg and Ag or may be one or more of Mg, Ag, Ca, Li, and Al.

[0069] The second substrate 160 is disposed on the common electrode 150 to face the first substrate 100 and seals the first organic layer 131, the second organic layer 132 and the third organic layer 140 between the first substrate 100 and the second substrate 160 from external air. Accordingly, the present invention may further include a sealing member (not shown) which bonds and seals the first substrate 100 and the second substrate 160 together. The sealing member (not shown) may be made of one or more materials selected from the group consisting of acrylic resin, methacrylic resin, polyisoprene, vinyl resin, epoxy resin, urethane resin, and cellulose resin.

[0070] The arrangement of a plurality of pixel regions of the organic light-emitting display device 500 as the current exemplary embodiment according to the principles of the present invention will now be described with reference to FIG. 1.

[0071] Referring to FIG. 1, a plurality of pixel regions may be arranged in first through fourth pixel columns L1 through L4 which are parallel to each other along a column direction.

[0072] The first pixel column L1 and the fourth pixel column L4 may include the first pixel regions 10 arranged successively. That is, in the first pixel column L1 and the fourth pixel column L4, each of the first pixel regions 10 may neighbor different first pixel regions 10 respectively on both sides thereof in the column direction. The second pixel column L2 may include the second pixel regions 20 and the third pixel regions 30 arranged alternately. The third pixel column L3 may include the second pixel regions 20 and the third pixel regions 30 arranged alternately in an order opposite to the order in which they are arranged in the second, pixel column L2.

[0073] In a row direction, each of the first pixel regions 10 may neighbor one of the second, pixel regions 20 on a side thereof and may neighbor one of the third pixel regions 30 on the other side thereof. Each of the second pixel regions 20 may neighbor the first pixel regions 10 respectively on both sides thereof in the row direction and may neighbor the third pixel regions 30 respectively on both sides thereof in the column direction. Each of the third pixel regions 30 may neighbor the first pixel regions 10 respectively on both sides

thereof in the row direction and may neighbor the second pixel regions 20 respectively on both sides thereof in the column direction.

[0074] In summary, the second pixel column L2, the first pixel column L1, the third pixel column L3 and the fourth pixel column L4 may be sequentially arranged in this order along the row direction, and the arrangement of a plurality of pixels may be a repetition of the arrangement of the second pixel column L2, the first pixel column L1, the third pixel column L3 and the fourth pixel column L4 in this order in the row direction.

[0075] FIG. 5 is a bottom perspective view of a portion of the organic common layer (i.e., the third organic layer 140) according to the exemplary embodiment of FIG. 1.

[0076] Referring to FIGS. 1 through 5, the third organic layer 140 includes first through fifth protruding patterns 191-1 through 191-5, each corresponding to the third pixel electrode 123. The first through fifth protruding patterns 191-1 through 191-5, each corresponding to the third pixel electrode 123, protrude further than regions 193, each corresponding to the first pixel electrode 121, and regions 192, each corresponding to the second pixel electrode 122. Specifically, each of the first pixel regions 10 includes the first organic layer 131 in addition to the third organic layer 140, and each of the second pixel regions 20 includes the second organic layer 132 in addition to the third organic layer 140. On the other hand, each of the third pixel regions 30 does not include another organic layer in addition to the third organic layer 140. Thus, the first through fifth protruding patterns 191-1 through 191-5 of the third organic layer 140 in each of the third pixel, regions 30 may protrude further toward the first substrate 100 than the regions 193, each corresponding to the first pixel electrode 121, by a thickness of the first organic layer 131, and may protrude further toward the first substrate 100 than the regions 192, each corresponding to the second pixel electrode 122, by a thickness of the second organic layer 332.

[0077] Each of the first through fifth protruding patterns 191-1 through 191-5 is disposed on the third pixel electrode 123. Each of the first through fifth protruding patterns 191-1 through 191-5 and the third organic layer 140 which is disposed on each of the first through fifth protruding patterns 191-1 through 191-5 may be made to emit light by a potential applied to the third pixel electrode 123 and a potential applied to the common electrode 150.

[0078] The first protruding pattern 191-1 may be located at an equal distance from each of the neighboring second through fifth protruding patterns 191-2 through 191-5. In addition, the second protruding pattern 191-2, the first protruding pattern 191-1 and the fourth protruding pattern 191-4 may be located in a straight line, and the third protruding pattern 191-3, the first protruding pattern 191-1 and the fifth protruding pattern 191-5 may be located in another straight line.

[0079] With reference to FIG. 6, a detailed description will hereinafter be given of the reason why the probability that the first or second organic layer 131 or 132 being deposited will intrude into each of the third pixel regions 30 in the organic light-emitting display device 500 constructed as the current exemplary embodiment is reduced.

[0080] FIG. 6 is a layout view of the organic light-emitting display device 500 of FIG. 1 constructed as the exemplary embodiment according to the principles of the present invention.

[0081] The resolution of a display device denotes the number of main pixels, each being a minimum unit that can display a desired color. Therefore, the area occupied by one main pixel is limited in order to obtain the same resolution in the same area.

[0082] Referring to FIG. 6, in the organic light-emitting display device 500, the first pixel regions 10 are placed in all main pixels P, respectively, and one of the second pixel regions 20 or one of the third pixel regions 30 is placed in one main pixel P. Therefore, only two pixels are included in one main pixel P. The color of light emitted from each of the first pixel regions 10 included in all main pixels P is a color to which human vision is sensitive at high resolution. When the color of one main pixel P is corrected by that of the second pixel region 20 or the third pixel region 30 included in a neighboring main pixel P, even if only two pixels are included in one main pixel P, a desired color can be expressed. Therefore, the same resolution can be obtained in the same area by using a smaller number of pixels, compared with a conventional display device in which three red, green and blue pixels are included in one main pixel.

[0083] In order to prevent a non-emitting region of a display device from, being seen, a ratio of the total area of pixels in one main pixel P to the area of the main pixel P may be maintained at a predetermined value or higher. In the conventional display device in which three red, green and blue pixels are included in one main pixel, two sections are required between the pixels. However, in the organic light-emitting display device 500 constructed as the current exemplary embodiment, since only two pixels are included in one main pixel P, there is only one section between the pixels. Therefore, even when the ratio of the total area of pixels in one main pixel P to the area of the main pixel P is maintained at the predetermined, value or higher, the distance between the pixels in the row direction may be greater than that in the conventional display device. Therefore, since the distance between each of the third pixel regions 30 and one of the first pixel regions 10 which neighbors the third pixel region 30 in the row direction is increased compared with that in the conventional display device, when the first organic layer 131 is deposited in each of the first pixel regions 10 using a fine metal mask, the probability that the first organic layer 131 will intrude into each of the third pixel regions 30 is reduced, thereby reducing a pixel defect rate.

[0084] Even when the ratio of the total area of pixels in one main pixel P to the area of the main pixel P is maintained at the predetermined value, a distance D8 between, a second pixel region 20 and a first pixel region 10 in a main pixel P may be greater than the distance between pixels in a main pixel of the conventional display device, and a length D6 of the second pixel region 20 in the column direction may be shorter than a length D5 of the first pixel region 10 in the column direction. Likewise, a distance D1 between a third pixel region 30 and a first, pixel region 10 in a main pixel P may be greater than the distance between pixels in a main pixel of the conventional display device, and the length D of the third pixel region 30 in the column direction may be shorter than the length D5 of the first pixel region 10 in the column direction. Accordingly, a distance D3 between each of the third pixel regions 30 and one of the second pixel regions 20 which neighbors the third pixel region 30 in the column direction is greater than that in the conventional display device. Thus, when the second organic layer 132 is deposited in each of the second pixel regions 20 using a fine metal mask, the probability that the

second organic layer 132 will intrude into each of the third pixel regions 30 is reduced, thereby reducing the pixel defect rate.

[0085] In some embodiment according to the principles of the present invention, a distance D3 between each of the second pixel regions 20 and one of the third pixel regions 30 which neighbors the second pixel region 20 is smaller than a distance D1 between each of the third pixel regions 30 and one of the first pixel regions 10 which neighbors the third pixel region 30 in a column direction.

[0086] FIG. 7 is a layout view of an organic light-emitting display device 510 constructed as another exemplary embodiment according to the principles of the present invention. FIG. 8 is a cross-sectional view taken along line VIII-VIII' of FIG. 7.

[0087] Referring to FIGS. 7 and 8, the organic light-emitting display device 510 constructed as the current exemplary embodiment may include a plurality of spacers 50 in addition to elements included in the organic light-emitting display device 500 constructed as the previous exemplary embodiment.

[0088] The spacers 50 separate a first substrate 100 from a second substrate 160. In some embodiments of the present invention, the spacers 50 may be interposed between a plurality of pixels in a column direction, that is, between first pixel regions 10 in the column direction, and between second pixel regions 20 and third pixel regions 30 in the column direction.

[0089] The spacers 50 are formed on a pixel defined layer 90, and the pixel defined layer 90 and the spacers 50 may be integrally formed of a photosensitive material by a photographic process or a photolithographic process. That is, the pixel defined layer 90 and the spacers 50 may be formed together by adjusting the amount of exposure using a halftone exposure process. However, the present invention is not limited thereto. The pixel defined layer 90 and the spacers 50 can also be sequentially or separately formed and can be independent structures made of different materials.

[0090] The organic light-emitting display device 510 constructed as the current exemplary embodiment includes the spacers 50 respectively on both sides of each of the third pixel regions 30 in the column direction. In this case, a higher barrier may be formed between each of the third pixel regions 30 and one of the second pixel regions 20 which is adjacent to the third pixel region 30 in the column direction than when only the pixel defined layer 90 but no spacer 50 exists between them. Therefore, when a second organic layer 132 is deposited, the probability that the second organic layer 132 will intrude into the region of each of the third pixel regions 30 is reduced, thereby reducing the pixel defect rate.

[0091] FIG. 9 is a layout view of an organic light-emitting display device 520 constructed as another exemplary embodiment according to the principles of the present invention. FIG. 10 is a cross-sectional view taken along line X-X' of FIG. 9.

[0092] Referring to FIGS. 9 and 10, the organic light-emitting display device 520 constructed as the current exemplary embodiment may include spacers 50 arranged in a row direction of a plurality of pixels, in addition to elements included in the organic light-emitting display device 510 according to the previous exemplary embodiment of FIG. 7.

[0093] The organic light-emitting display device 520 constructed as the current exemplary embodiment includes the spacers 50 respectively on both sides of each of third pixel

regions 30 not only in a column direction but also in a row direction. In this case, a higher barrier may be formed between each of the third pixel regions 30 and one of first pixel regions 10 which is adjacent to the third pixel region 30 in the row direction than when only a pixel defined layer 90 but no spacer 50 exists between them. Therefore, when a first organic layer 131 is deposited, the probability that the first organic layer 131 will intrude into the region of each of the third pixel regions 30 is reduced, thereby reducing the pixel defect rate.

[0094] FIG. 11 is a layout view of an organic light-emitting display device 530 constructed as another exemplary embodiment according to the principles of the present invention.

[0095] The organic light-emitting display device 530 constructed as the current exemplary embodiment of the present invention includes a first pixel column L1 and second and third pixel columns L2 and L3 which are disposed respectively on both sides of the first pixel column L1 in a row direction. The first pixel column L1 and the fourth pixel column L4 may include the first pixel regions 10 arranged successively. The second pixel column L2 and the third pixel column L3 may include the second pixel regions 20 and the third pixel regions 30 arranged alternately, and in the same order. In addition, spacers 50 may be interposed between third pixel regions 30 and second pixel regions 20 and may further be interposed between the third pixel regions 30 and first pixel regions 10.

[0096] As in the organic light-emitting display devices 500 through 520 in the previous exemplary embodiments, in the organic light-emitting display device 530 according to the current exemplary embodiment, the distance between each of the third pixel regions 30 and one of the second pixel regions 20 which neighbors the third pixel region 30 in a column direction and the distance between each of the third pixel regions 30 and one of the first pixel regions 10 which neighbors the third pixel region 30 in the row direction are greater than those in a conventional display device. Accordingly, when an organic layer is deposited in each of the first pixel regions 10 or each of the second pixel regions 20, the probability that the organic layer will intrude into each of the third pixel regions 30 is reduced, thereby reducing the pixel defect rate.

[0097] In addition, the organic light-emitting display device 530 constructed as the current exemplary embodiment includes the spacers 50 in the row and column directions of a plurality of pixels. In this case, a higher barrier may be formed between the pixels than when only a pixel defined layer 90 but no spacer 50 exists between them. Therefore, when an organic layer is deposited in each of the first pixel regions 10 or each of the second pixel regions 20, the probability that the organic layer will intrude into each of the third pixel regions 30 is reduced, thereby reducing the pixel defect rate.

[0098] More details of the organic light-emitting display devices according to the above-described embodiments and other various embodiments will be described, together with a method of manufacturing an organic light-emitting display device as exemplary embodiments according to the principles of the present invention.

[0099] FIGS. 12A, 13A, 14A, 15A and 16A are layout views sequentially illustrating processes in a method of manufacturing an organic light-emitting display device as an exemplary embodiment according to the principles of the present invention. FIGS. 12B, 13B, 14B, 15B and 16B are cross-sectional views respectively taken along line XIIb-

XIIb' of FIG. 12A, line XIIIb-XIIIb' of FIG. 13A, line XIVb-XIVb' of FIG. 14A, line XVb-XVb' of FIG. 15A, and line XVIb-XVIb' of FIG. 16A. An exemplary method of manufacturing an organic light-emitting display device is illustrated in these drawings.

[0100] Referring to FIGS. 12A and 12B, a first substrate 100 is prepared. The preparing of the first substrate 100 may include forming a plurality of pixel driving portions 110, which are included in a driving element layer 104, on a first insulating substrate 102.

[0101] Referring to FIGS. 13A and 13B, a pixel defined layer 90 including a plurality of apertures 90a arranged in a matrix is formed on the first substrate 100. In some other embodiments of the present invention, a process of forming spacers on the pixel defined layer 90 may further be performed.

[0102] Referring to FIGS. 14A and 14B, first through third pixel electrodes 121 through 123 are formed in the apertures 90a of the pixel defined layer 90. Each of the first pixel electrodes 121 may neighbor one of the second pixel electrodes 122 on a side thereof in a row direction and may neighbor one of the third pixel electrodes 123 on the other side thereof in the row direction. In addition, each of the first pixel electrodes 121 may neighbor different first pixel electrodes 121 respectively on both sides thereof in a column direction. Each of the second pixel electrodes 122 may neighbor the first pixel electrodes 121 respectively on both sides thereof in the row direction, and may neighbor the third, pixel electrodes 123 respectively on both sides thereof in the column direction. Each of the third pixel electrodes 123 may neighbor the first pixel electrodes 121 respectively on both sides thereof in the row direction and may neighbor the second pixel electrodes 122 respectively on both sides thereof in the column direction.

[0103] Referring to FIGS. 15A and 15B, a first organic layer 131 and a second organic layer 132 are formed by deposition processes. The first organic layer 131 and the second organic layer 132 may be deposited using separate fine metal masks. The first organic layer 131 and the second organic layer 132 may be sequentially formed in this order or in the reverse order.

[0104] Referring to FIGS. 16A and 16B, a third organic layer 140 is formed on the first organic layer 131 and the second organic layer 132 as a common layer. The third organic layer 140 may be deposited, as an organic common layer, on the whole surface of the first substrate 100 having the first and second organic layers 131 and 132 without using a fine metal mask.

[0105] Then, a common electrode 150 is formed on the third organic layer 133 as a common layer.

[0106] Finally, a second substrate 160 is placed on the common electrode 150. The second substrate 160 may be placed on the common electrode 150 to face the first substrate 100. The placing of the second substrate 160 may include sealing and bonding the first substrate 100 and the second substrate 160 together using a sealing member (not shown), thereby preventing external air from getting into the first organic layer 131, the second organic layer 132, and the third organic layer 140.

[0107] In concluding the detailed description, those skilled in the art will appreciate that many variations and modifications can be made to the preferred embodiments without substantially departing from the principles of the present invention. Therefore, the disclosed preferred embodiments of

the invention are used in a generic and descriptive sense only and not for purposes of limitation.

What is claimed is:

1. An organic light-emitting display device, comprising;
 a substrate;
 a plurality of pixel electrodes arranged in a matrix on the substrate, wherein the pixel electrodes comprise a plurality of first pixel electrodes, a plurality of second pixel electrodes, and a plurality of third pixel electrodes;
 a first organic layer disposed on the first pixel electrode;
 a second organic layer disposed on the second electrode;
 and
 an organic common layer disposed on the first organic layer, the second organic layer and the third pixel electrodes; wherein
 along an n-th pixel column, the first pixel electrodes and the second pixel electrodes are arranged alternately, and
 along an (n+1)-th pixel column which is adjacent to the n-th pixel column, the third pixel electrodes is arranged repeatedly, wherein n is a natural number,
 in regions of the organic common layer which overlaps the first pixel, electrodes, the first organic layer emits green light and the organic common layer does not emit light,
 in regions of the organic common layer which overlaps the second pixel electrodes, the second organic layer emits red light and the organic common layer does not emit light, in regions of the organic common layer which overlaps the third pixel electrodes, the common organic layer emits blue light.

2. The display device of claim 1, wherein a distance between each of the second pixel electrodes and one of the third pixel electrodes which, neighbors the second pixel electrode is larger than a distance between each of the third pixel electrodes and one of the first pixel electrodes which neighbors the third pixel electrode in a row direction.

3. The display device of claim 1 further comprising spacers formed on regions of the substrate between the second pixel electrodes and the third pixel electrodes.

4. The display device of claim 1, further comprising spacers formed on regions of the substrate between the second pixel electrodes and the first pixel electrodes.

5. The display device of claim 1, further comprising first spacers formed on the regions of the substrate between the second pixel electrodes and the third pixel electrodes,

second spacers formed on the regions of the substrate between the second pixel electrodes and the first pixel electrodes, and

third spacers formed on the regions of the substrate between the third pixel electrodes and the first pixel electrodes.

6. The display device of claim 1, further comprising a pixel defined layer disposed on the substrate and comprising a plurality of apertures arranged in a matrix,

wherein the pixel electrodes are formed in the apertures on the substrate.

* * * * *

专利名称(译)	有机发光显示装置及其制造方法		
公开(公告)号	US20160020260A1	公开(公告)日	2016-01-21
申请号	US14/868093	申请日	2015-09-28
[标]申请(专利权)人(译)	三星显示有限公司		
申请(专利权)人(译)	三星DISPLAY CO., LTD.		
当前申请(专利权)人(译)	三星DISPLAY CO., LTD.		
[标]发明人	IM JA HYUN LEE KWAN HEE KIM BEOM SEOK		
发明人	IM, JA-HYUN LEE, KWAN-HEE KIM, BEOM-SEOK		
IPC分类号	H01L27/32 H01L51/52		
CPC分类号	H01L27/3218 H01L51/525 H01L27/326 H01L27/3216 H01L27/3246		
优先权	1020110057028 2011-06-13 KR		
其他公开文献	US9455305		
外部链接	Espacenet USPTO		

摘要(译)

一种有机发光显示装置，包括基板，在基板上以矩阵布置的多个像素电极，以及覆盖像素电极的有机公共层。像素电极包括多个第一像素电极，多个第二像素电极和多个第三像素电极。第n像素列包括第二像素电极；交替排列的第三像素电极，与第n像素列相邻的第(n+1)像素列包括第一像素电极，和与第n像素电极相邻的第(n+2)像素列第(n+1)像素列包括交替排列的第二像素电极和第三像素电极，其中n是自然数。第二和第三像素电极中的一个设置在第n行像素列中，而第二和第三像素电极中的另一个设置在同一行中的第(n+2)像素列中。

